

## Audio input

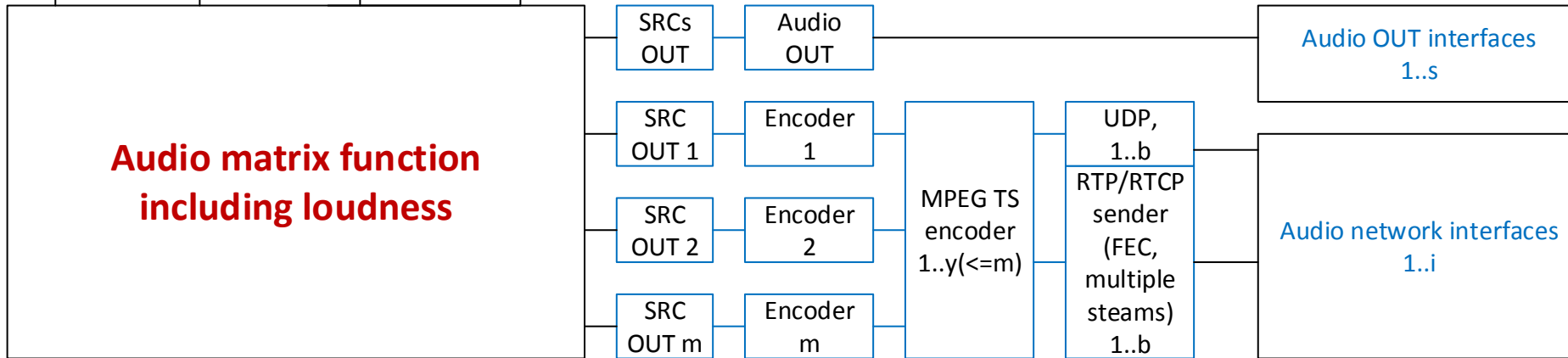

## Audio output

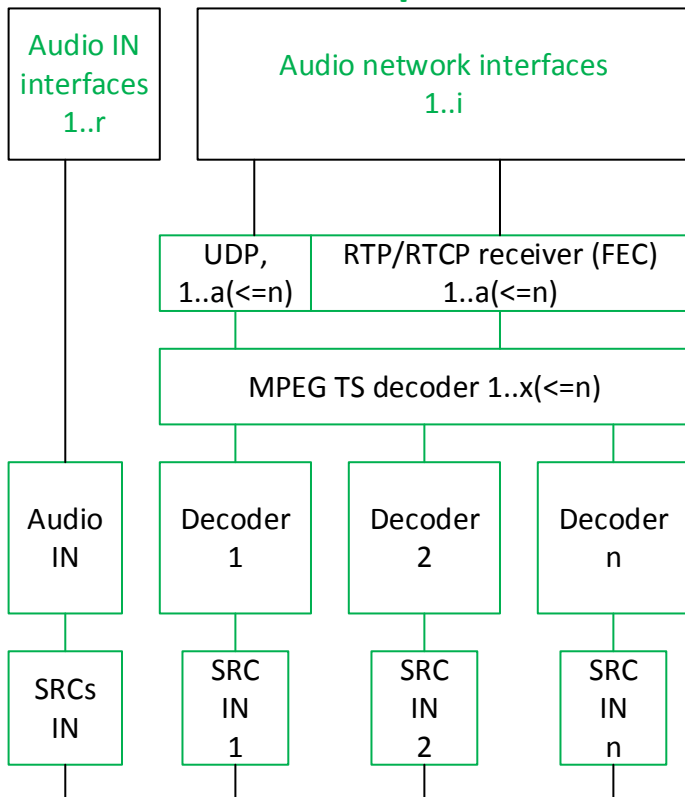
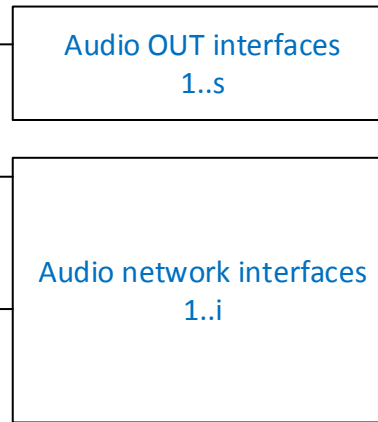

# Audio input (m channels)

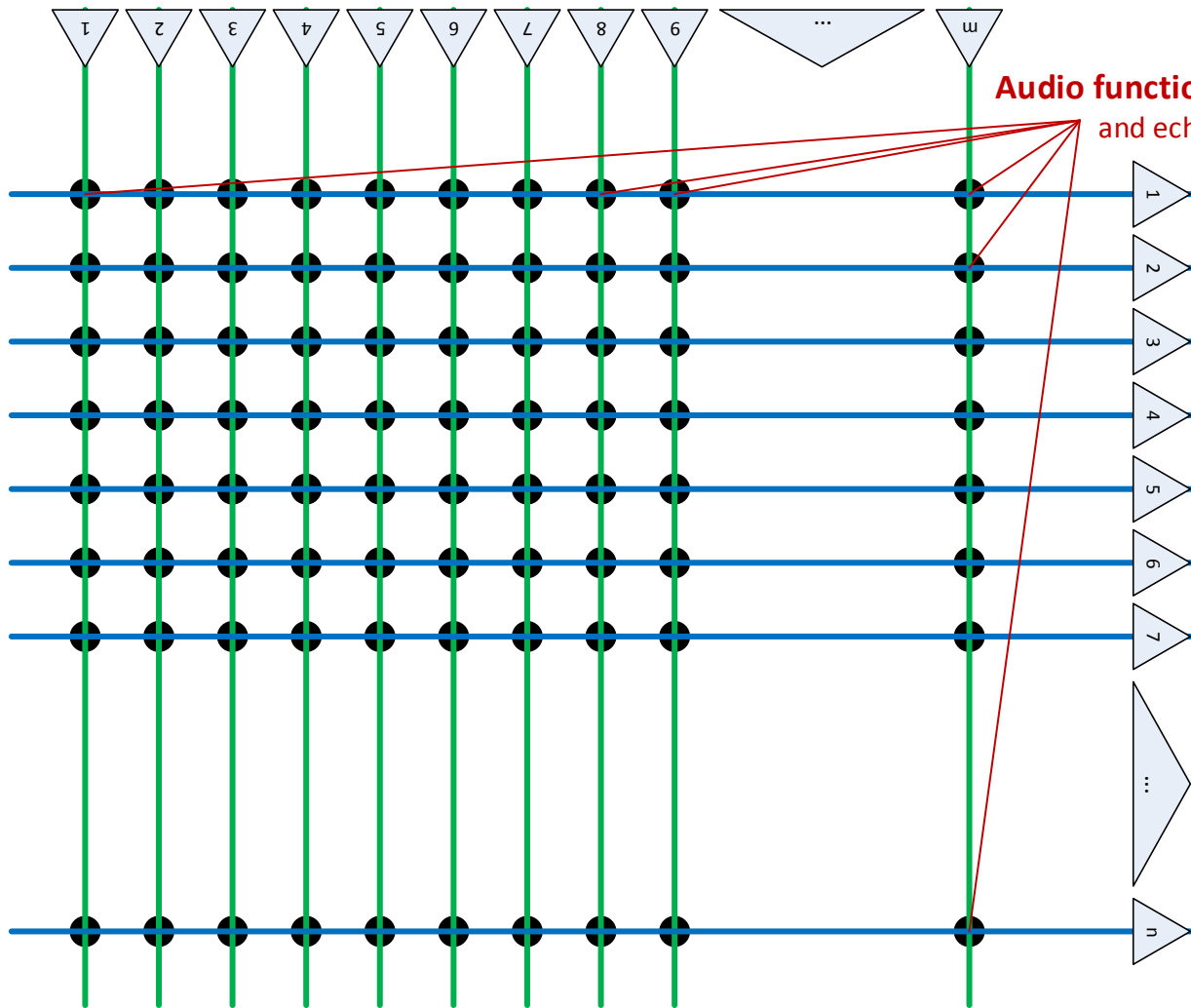

Audio functions like loudness, gain, limiter and echo are available on every node

# Audio output (n channels)

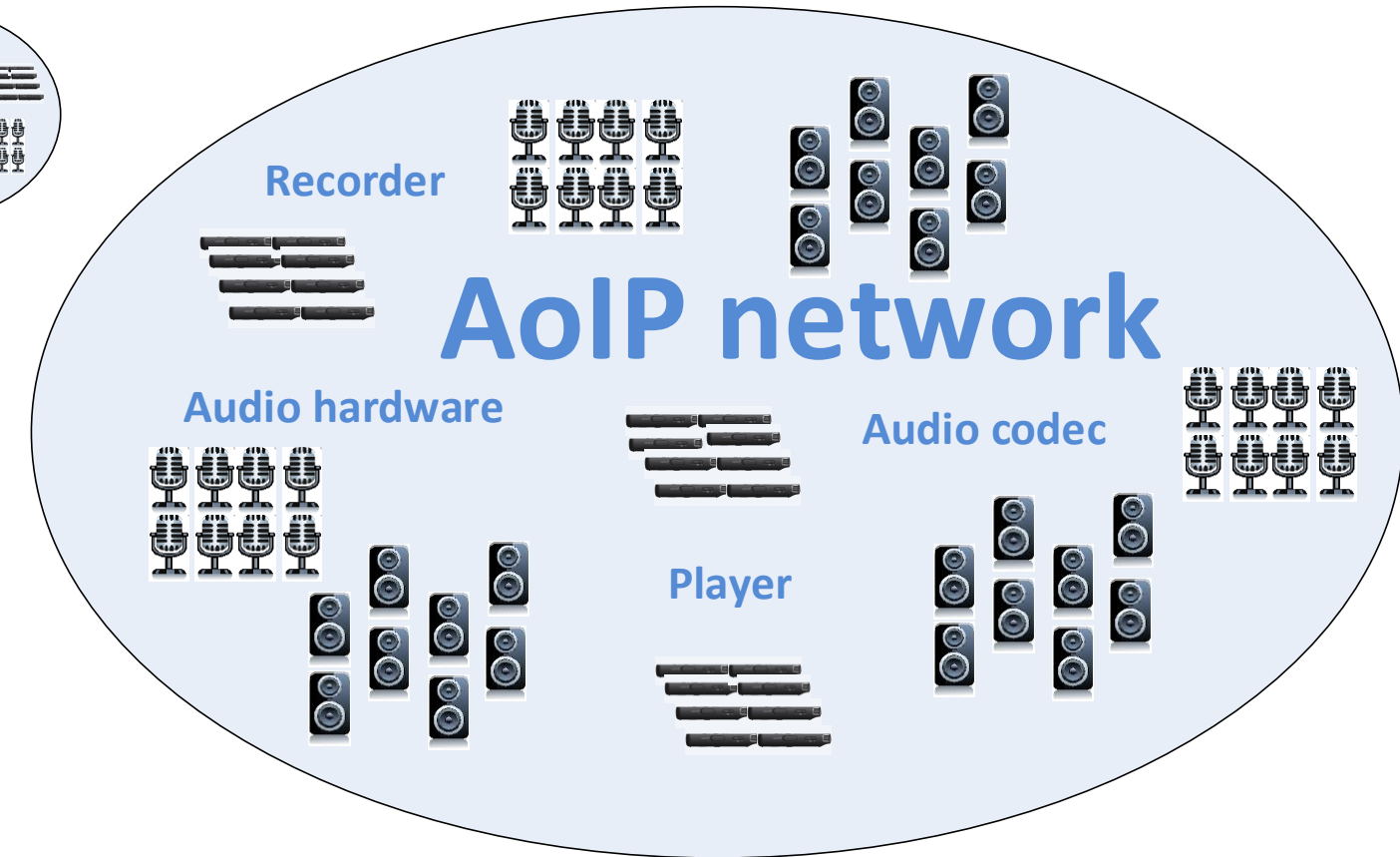
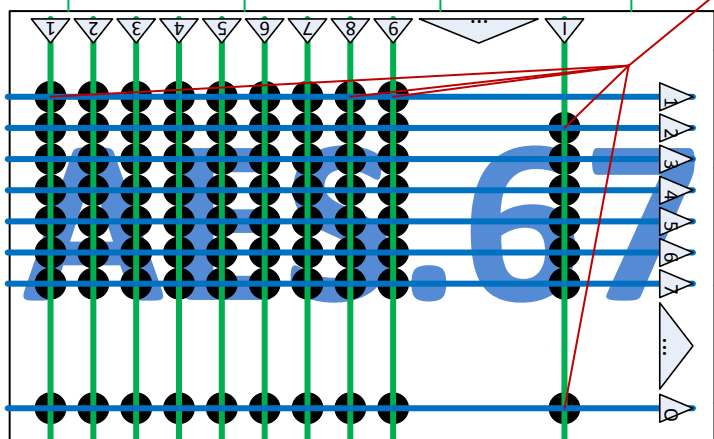
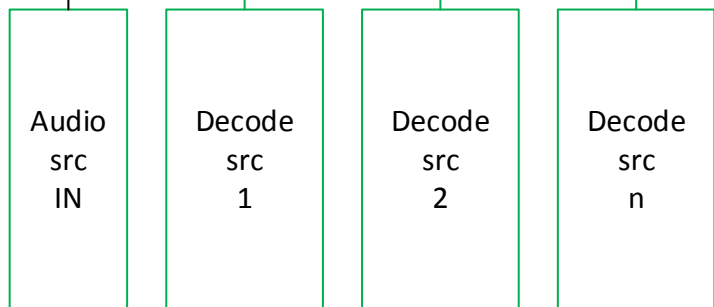
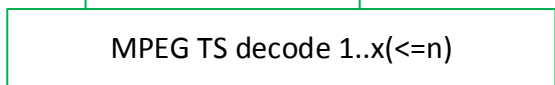
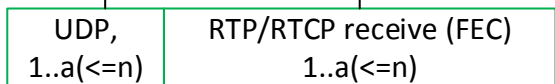
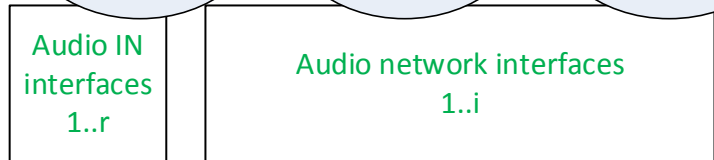
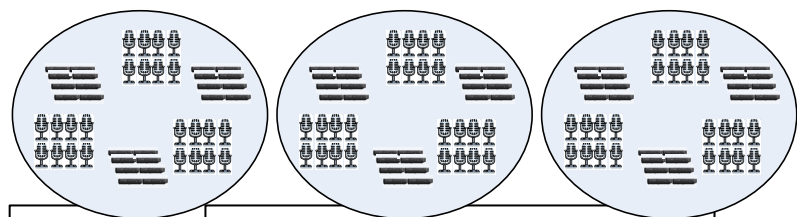

**Audio functions** like loudness, gain, limiter and echo cancellation are available on every node

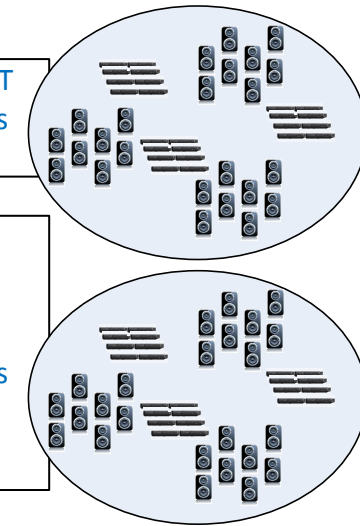
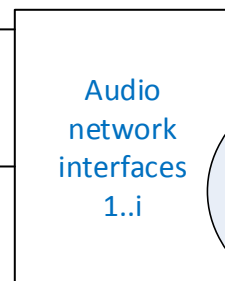
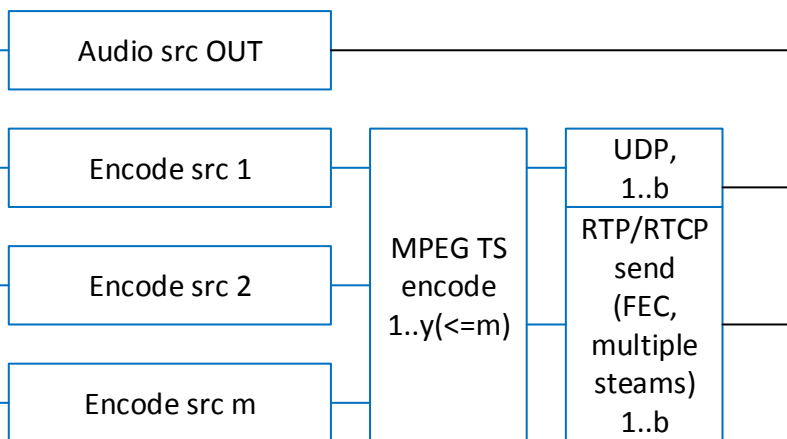

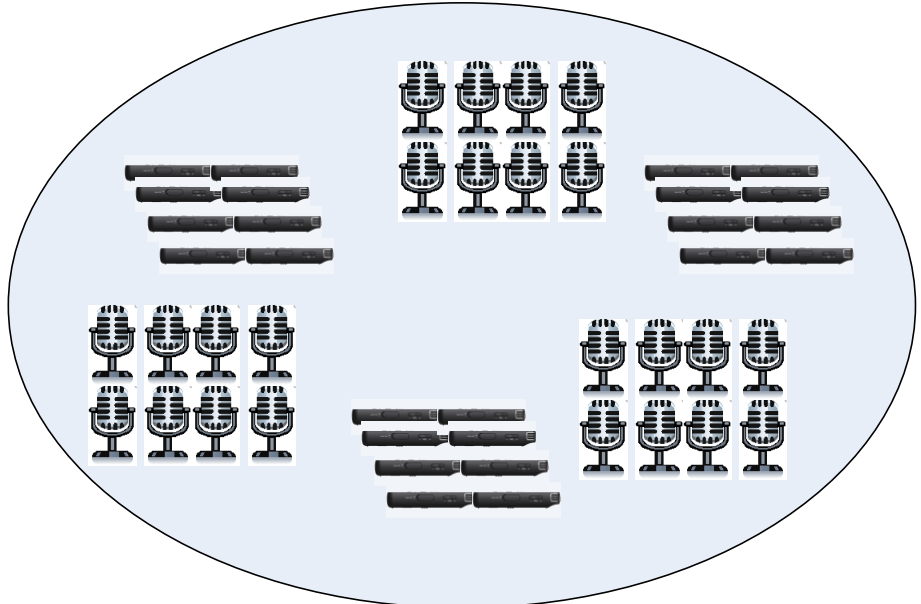



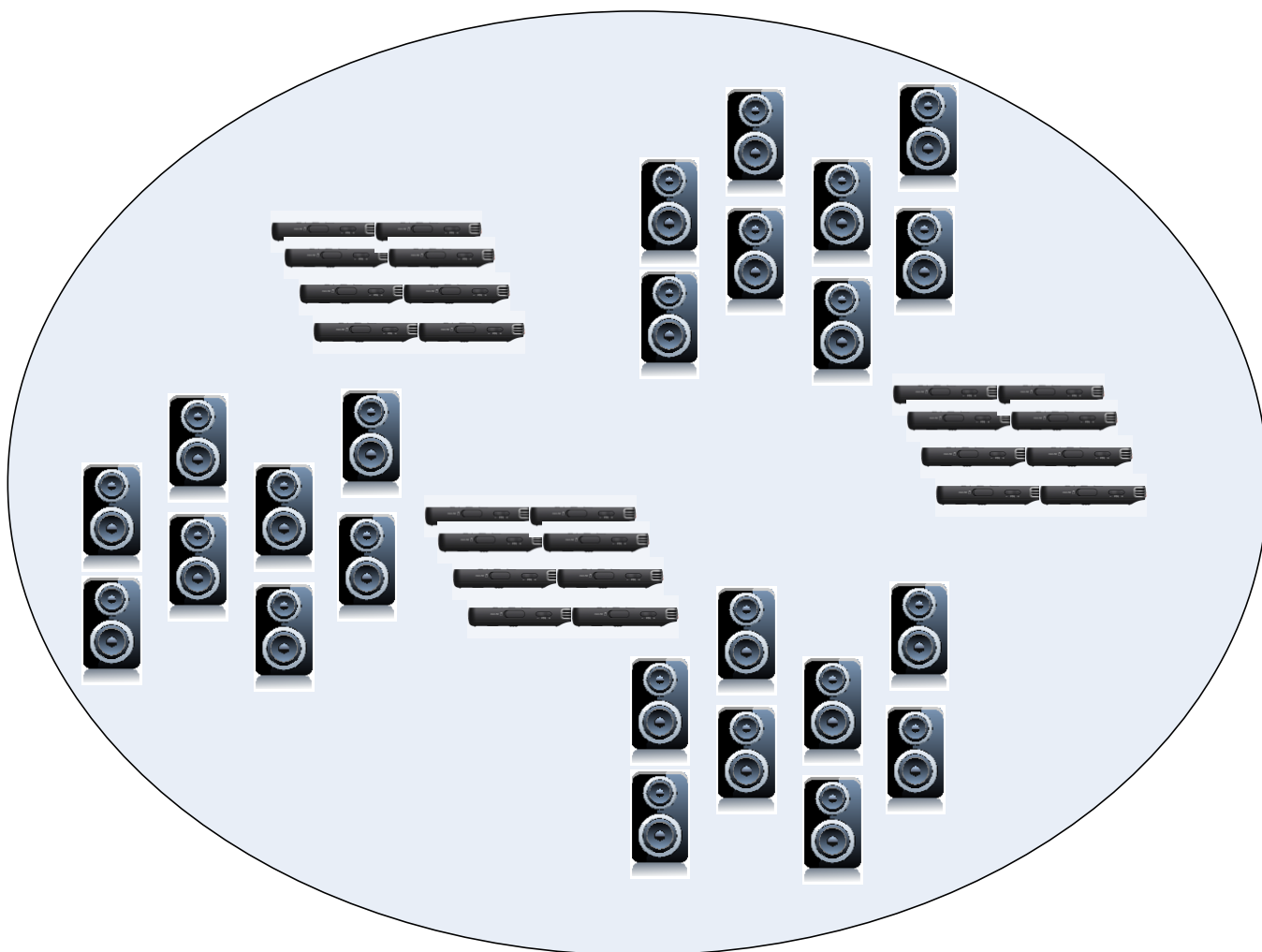

Recorder



# AoIP network



Audio hardware

Audio codec



Player

